

Wagon Tiplers and Positioners

Wagon tiplers are used to unload bulk material from wagons, including materials such as coal, coke, lignite, iron ore, limestone, dolomite, among others. A complete wagon tipler system includes the positioning system, car dumper, and underground hopper along with feeders below the hopper to release bulk material. Depending on the application, this machine can be designed with a single, tandem, triple, or quadruple dumper frame. Every wagon tipler system is engineered to meet customer needs based on the type of bulk material that will be unloaded.



Brevini™ Industrial Planetary Gearboxes
High Power Series

- Extensive ratio range
- Supports torque range up to 2,200 kNm [1,600,000 ft lbs]
- Increased thermal capacity due to shared oil chamber



Brevini™ Planetary Gearboxes
Slewing Series

- Improved thermal capacity
- Robust design
- Reliable operation, engineered for harsh conditions

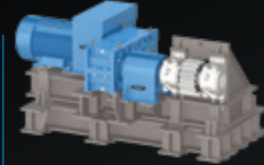

Brevini EvoMax™
Gearbox Series

- Complete drive system including base and bed plate
- Supports torque range up to 1,100 kNm [958,900 ft lbs]
- Spheroidal graphite cast iron housing

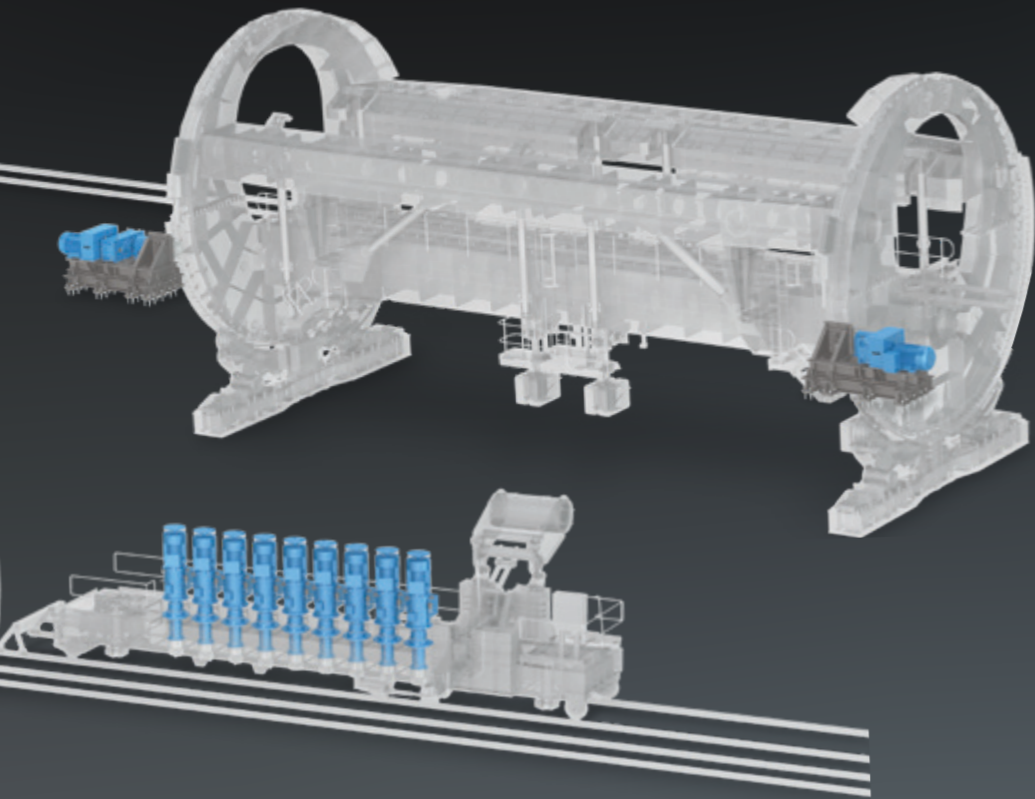

We offer customized solutions to meet a range of customer needs, including modular designs and add-on accessories.

Thickeners and Clarifiers

The principal task of a clarifier, also known as a juicer, is the separation of solids from the sugar cane liquid in order to minimize impurities and thereby obtain the purest juice possible. Juice is heated to help kill natural enzymes; flocculants are added as well as lime which brings the juice to a neutral pH value, a vital factor in sugar processing.

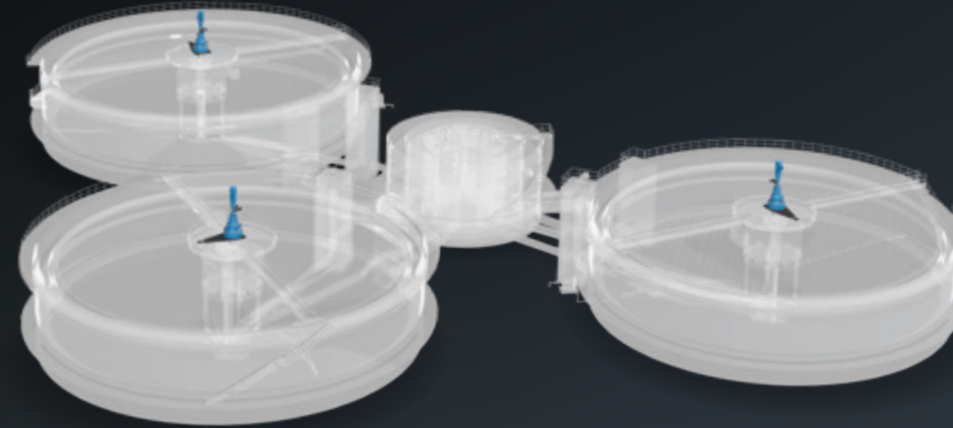

Brevini™ Industrial Planetary
Gearboxes – S Series

- Modular concept
- Extensive ratio range
- Supports torque range up to 2,200 kNm [1,600,000 ft lbs]
- Output supports design for heavy loads at low working speed
- Torque load cell system

Milling and Grinding

Once the nodular clinker issues from the sintering furnace, it needs to be ground down into a fine powdery substance. This can be done using different milling or grinding equipment: horizontal mills, hydraulic roller presses, or vertical roller mills. Horizontal mills, which are essentially large cylinders rotating horizontally or at a slight angle, mostly contain steel balls, although some mills use ceramic or rubber balls, which reduce the clinker to powder through impact and attrition.

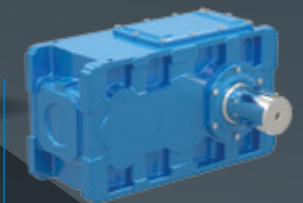
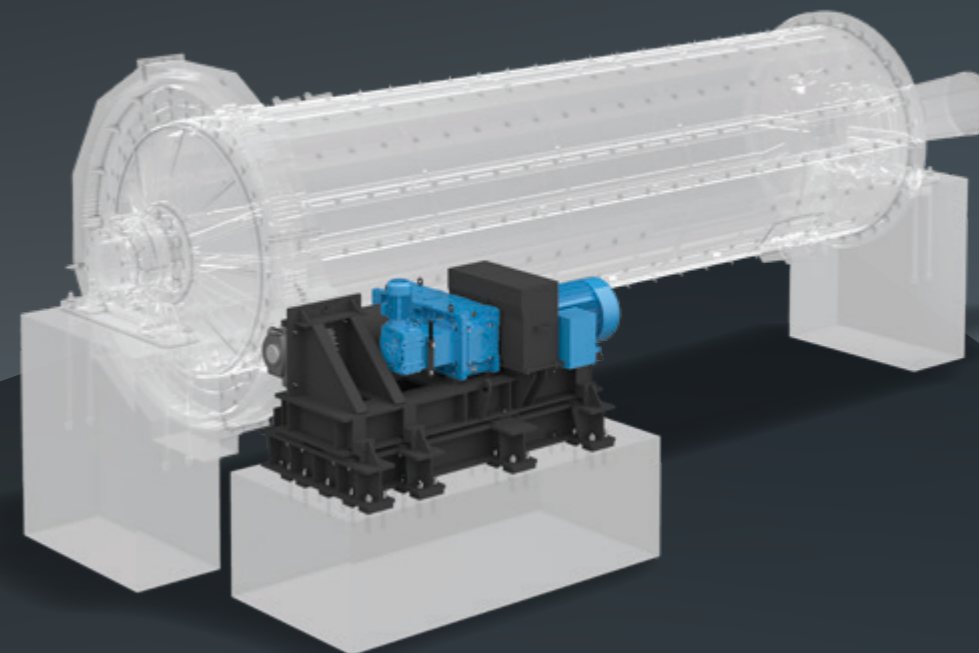

Brevini™ Helical Bevel Helical Series:
Brevini EvoMax™ and Posired 2

- Extensive ratio range
- Evomax supports torque range up to 310 kNm [228,700 ft lbs]
- Posired 2 supports torque ranging from 340kNm up to 1,100 kNm [812,000 ft lbs]
- Increased thermal capacity
- Spheroidal graphite cast iron housing available
- Diverse low-speed shaft options